



INA 2 1029LED

Categorías: [Empotrable Invisible](#), [Invisible](#)
Catálogo: [Escayola Integrada Invisible](#)

CARÁCTERÍSTICAS TÉCNICAS

Dimensiones:	400 × 200 × 45 mm
Color Luz °K:	3000K
Driver y LED:	Incluido
Material:	Aleación especial escayola – INESPLAST
Color:	Blanco
IP:	20
Medida Corte (mm):	403X203
Conformidad Europea:	CE + Rohs
Clase:	III



MEDIDAS / MEASURES



403x203mm

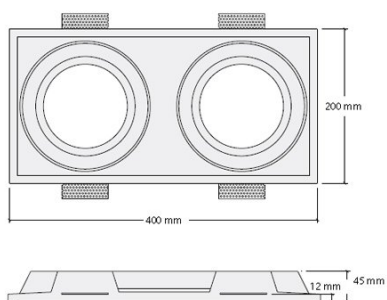

75 mm. Altura total con modulo led / Total Height with led module

